



Magnetic Autocontrol GmbH

Grienmatt 20
D-79650 Schopfheim
Phone. 07622 695 644
Techn. Support

Job number 5526,0032
Customer
Commission MicroDrive
End customer / Place of installation

Type MHTM - MicroDrive -traffic light red/green with lead time

Edit date 28.02.2012 by (short name) Probst Number of pages 6

Mounting panel Voltage supply

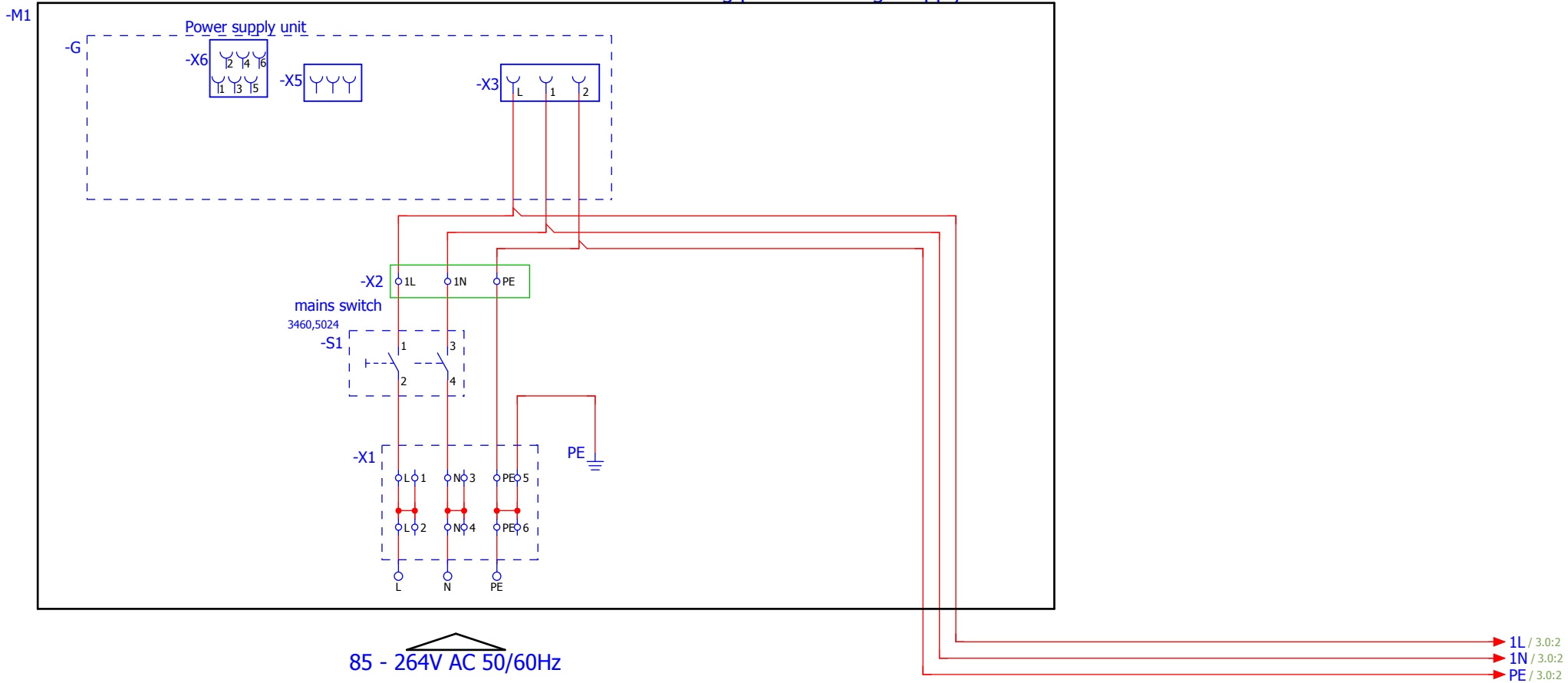

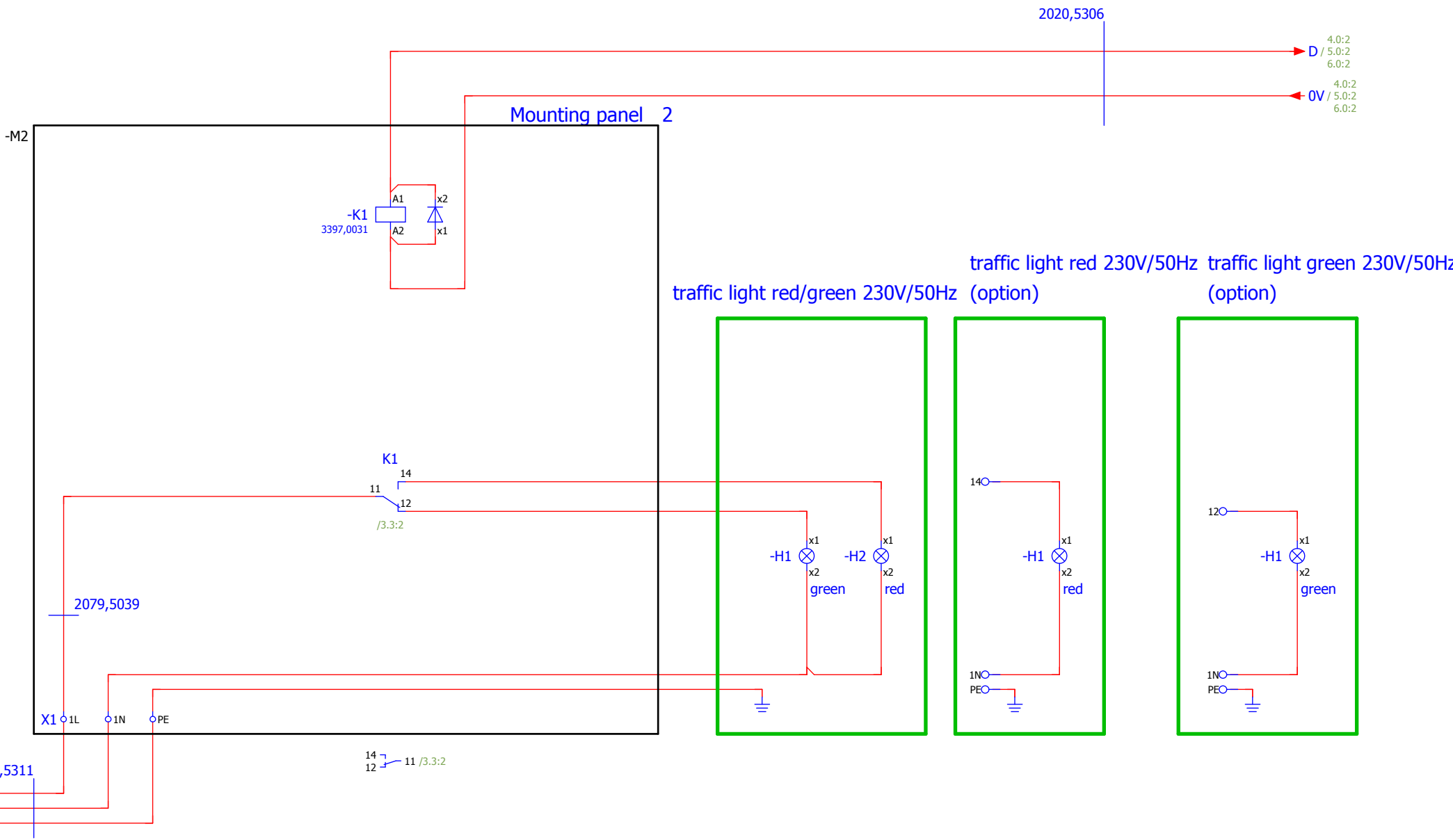

OPTION 1 signal light A

A1
/5.2:2
/6.2:2

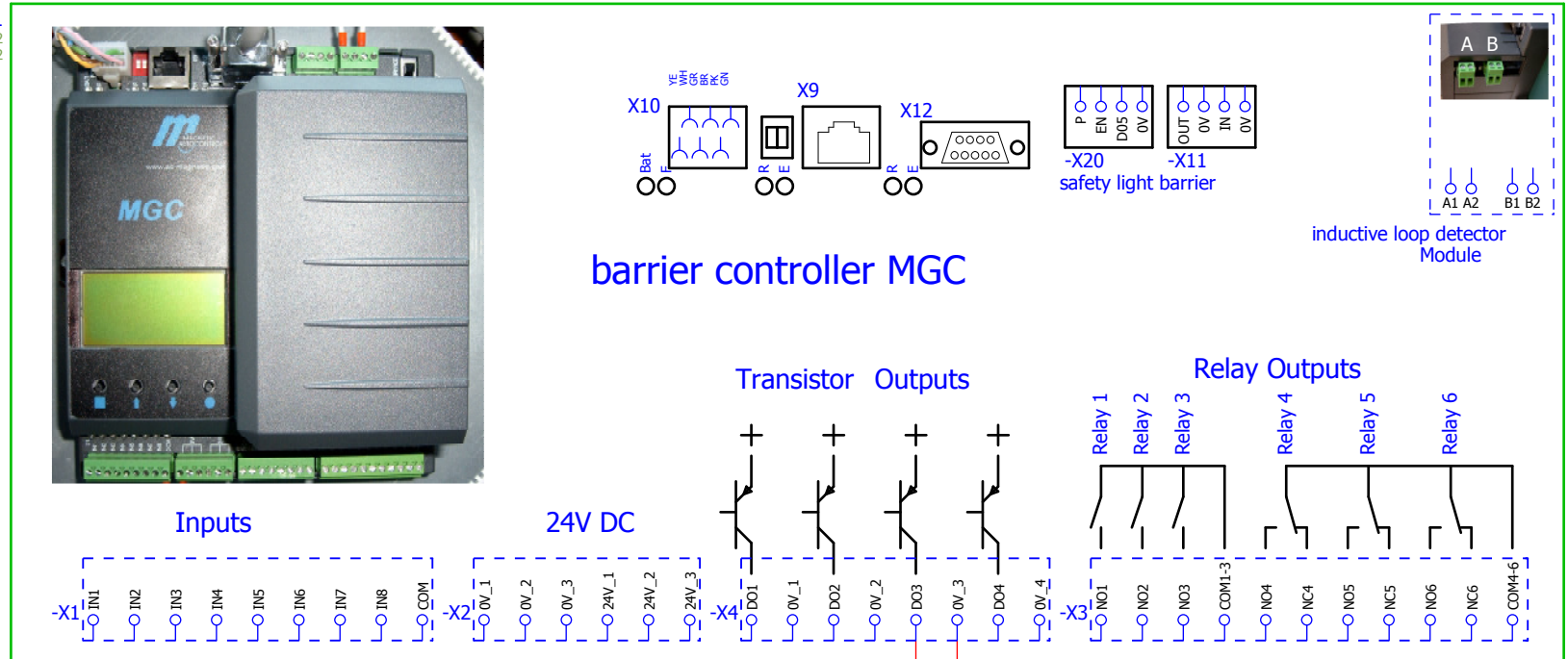

3.8:2 / D
3.8:2 / 0V

D03 = signal light A,select option " traffic light" in menu signal mode A

OPTION 2 signal light B

A1
/4.2:2
/6.2:2

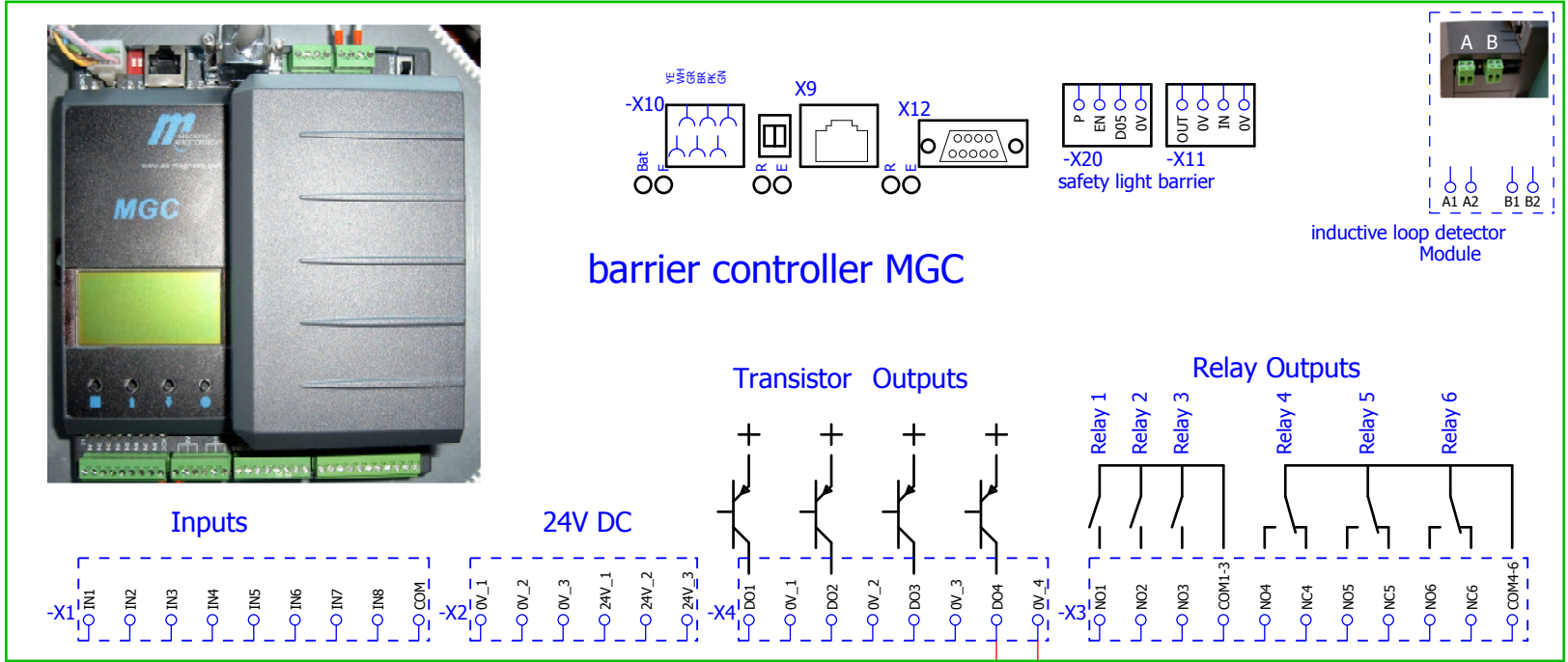

3.8:2 / D
3.8:2 / 0V

DO4 = signal light B, select option "traffic light" in menu signal mode B

OPTION 3 signal light C

A1
/4.2:2
/5.2:2

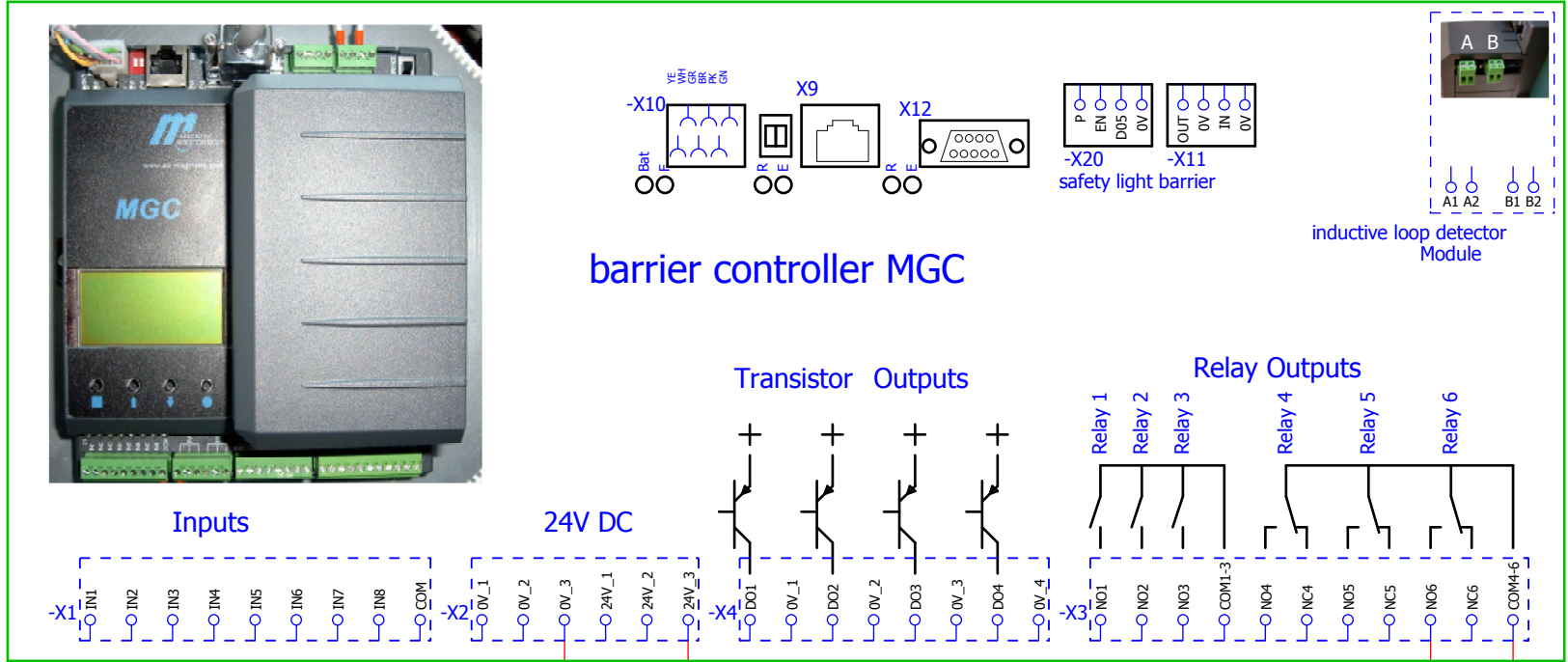

N06 = signal light C, select option "traffic light" in menu signal mode C

3.8:2 / D
3.8:2 / 0V